

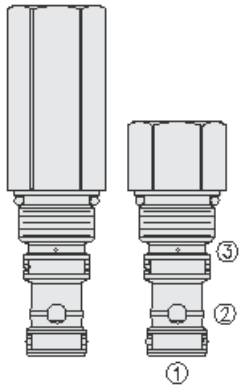

Overview



Description

The ep10-s35xx is a screw-in, cartridge style, pilot to close hydraulic directional element.

Operation

The valve is a spring-biased blocking valve which will shift to allow full flow from port 1 to 2 only when the pressure at port 1 exceeds the cumulative pressure of port 3 plus the bias spring pressure value.

Features

- Multiple function/application potential.
- Range of bias spring pressure options. Tall cap required for 160, M11, 230, and M15.9 spring options.
- Industry-common cavity.

Symbol

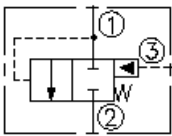

Ratings

Pressure Ratings

Pressure rating 345 bar (5000 psi)

Flow Ratings

Flow rating See performance graph
 Maximum internal leakage 164 ml/min (10 in³/min) - **Note:** At 207 bar (3000 psi)

Temperature Ratings

Operating fluid temperature	-40 to 100 °C (-40 to 212 °F)	- Note: With buna N seals
	-26 to 204 °C (-15 to 400 °F)	- Note: With fluorocarbon seals
Storage temperature	-26 to 204 °C (-15 to 400 °F)	- Note: With high durometer fluorocarbon seals
	-54 to 107 °C (-65 to 225 °F)	- Note: With polyurethane seals
Ambient temperature	-40 to 70 °C (-40 to 160 °F)	
	-40 to 90 °C (-40 to 194 °F)	

Operating Parameters

Fluids	Mineral based or synthetic hydraulic fluid with lubricating properties
Fluid viscosity range	7.4 to 420 cSt
Maximum operating contamination level	20/18/14 per ISO 4406

Properties

Unit weight	0.14 kg (0.31 lb)	- Note: EP10-S35
	0.27 kg (0.60 lb)	- Note: EP10-S35T
Internal wetted surface area	123 cm ² (19.0 in ²)	- Note: Ep10s35
	191 cm ² (29.6 in ²)	- Note: Ep10s35t



Performance

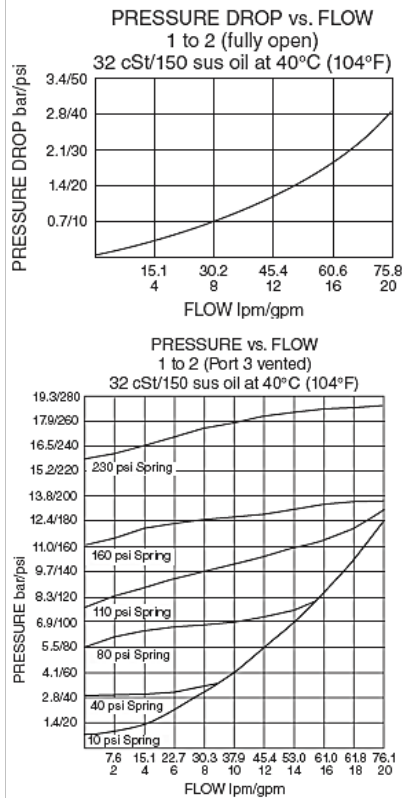

Dimensions

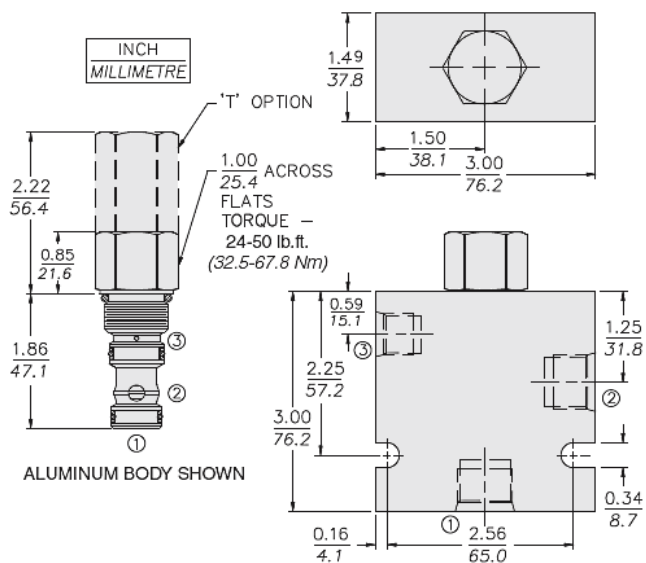

ORIFICE DISCS SHOULD NOT BE USED WITH THIS PRODUCT.

Installation Specifications

Cavity	VC10-S3
Cartridge installation torque	32.5 to 35.3 N-m (24 to 26 ft-lb)
Maximum allowable torque	67.8 N-m (50 ft-lb)
Orientation restriction	None

Accessories

Seal kit	SK10-S3X-MM	- Note: X = seal option
----------	-------------	-------------------------

Order Code



ORDERING INFORMATION
EP10-S35XX-X-XX-XXX

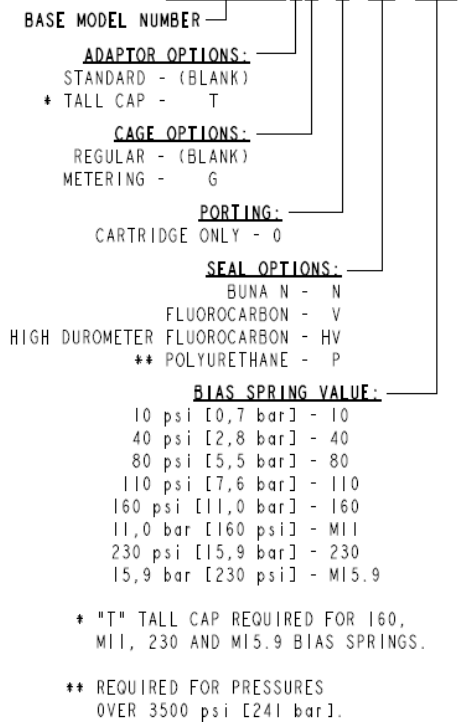

Model Options

EP10-S36CD-H-J-R

C Adaptor Option

CODE	DESCRIPTION
BLANK	Standard Cap
T	Tall Cap

H Line Body

CODE	DESCRIPTION
0	No Body
10T	Aluminum body SAE #10 ports
10TD	Ductile Iron body SAE #10 ports

J Seal

CODE	DESCRIPTION
N	Buna-N
V	Fluorocarbon
P	Polyurethane
U	PPDI Urethane

R Spring

CODE	DESCRIPTION
10	10 psi Bias Spring
40	40 psi Bias Spring
80	80 psi Bias Spring
110	110 psi Bias Spring
M11	11 bar Bias Spring
160	160 psi Bias Spring



CODE	DESCRIPTION
230	230 psi Bias Spring
M15.9	15.9 bar Bias Spring