

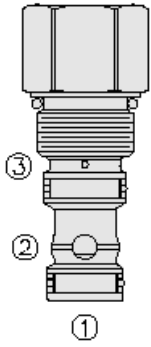

Overview



Description

A screw-in, cartridge-style, spool-type, spring-biased, pressure-reducing logic element.

Operation

The ER10-S30 acts as the pressure-reducing element when used in conjunction with a pilot relief valve connected to port 3. The outlet port 1 is connected to the spring chamber and port 3 through the orifice in the spool. When the pilot relief valve is closed, the pressure-reducing element is completely open and allows oil to flow from the inlet at port 2 to the outlet at port 1 with minimum pressure drop. On attainment of a pre-determined pressure at port 1, the spool shifts to increase pressure drop between ports 2 and 1, thereby reducing and maintaining pressure at port 1 equal to the preset pilot pressure at port 3.

Features

- Spring-biased, spool type logic element
- For use in conjunction with a pilot relief valve
- Hardened spool and cage for long life.
- Corrosion-resistant plating option available.
- Industry-common size.

Symbol

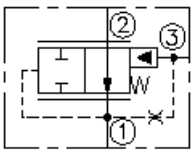

Ratings

Pressure Ratings

Pressure rating 350 bar (5000 psi)

Flow Ratings

Flow rating See performance graph

Temperature Ratings

Operating fluid temperature	-40 to 100 °C (-40 to 212 °F)	- Note: With buna N seals
	-26 to 204 °C (-15 to 400 °F)	- Note: With fluorocarbon seals
Storage temperature	-54 to 107 °C (-65 to 225 °F)	- Note: With polyurethane seals
	-40 to 70 °C (-40 to 160 °F)	
Ambient temperature	-40 to 90 °C (-40 to 194 °F)	

Other Ratings

Corrosion protection 960 hr salt spray per ASTM b117 (ger10-s30)

Operating Parameters

Fluids	Mineral based or synthetic hydraulic fluid with lubricating properties
Fluid viscosity range	7.4 to 420 cSt
Maximum operating contamination level	20/18/14 per ISO 4406

Properties

Unit weight	0.15 kg (0.32 lb)
Internal wetted surface area	143 cm ² (22.17 in ²)



Performance

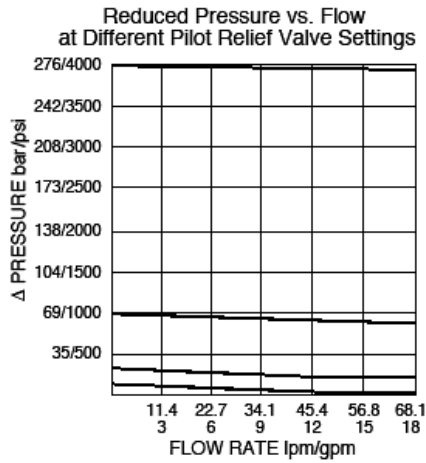
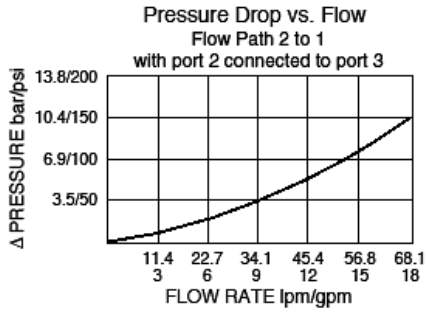

Dimensions

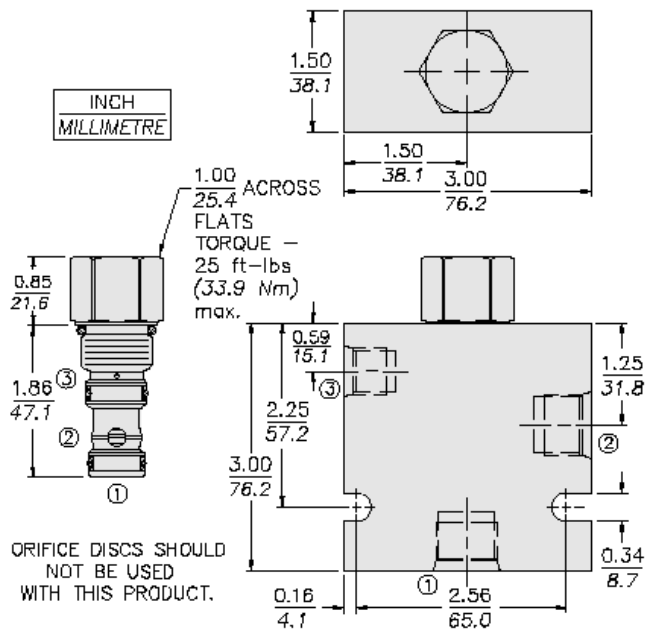

Installation Specifications

Cavity	VC10-S3
Cartridge installation torque	32.6 to 35.4 N-m (24 to 26 ft-lb)
Orientation restriction	None

Accessories

Seal kit	SK10-3X-MM	- Note: X = seal option
----------	------------	-------------------------



Order Code

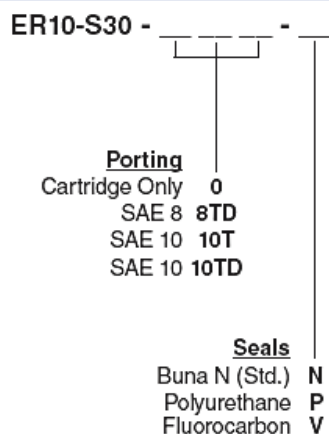

Note: Polyurethane seals are recommended for operation over 241 bar (3500 psi)

Model Options

ER10-S30-H-J

H Line Body

CODE	DESCRIPTION
0	No Body

J Seal

CODE	DESCRIPTION
N	Buna-N
V	Fluorocarbon
P	Polyurethane
U	PPDI Urethane