

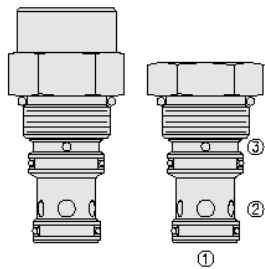

Overview

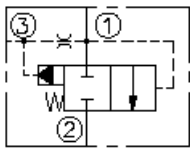

Symbol



Description

The EV16-S34 is a screw-in, cartridge style, hydraulic directional element.

Operation

The valve is a spring-biased blocking valve with an internal pilot orifice. The EV16-S34 shifts to allow full flow from port 1 to port 2 only when port 3 is vented to create a pressure drop across the internal orifice which exceeds the pressure of the bias spring value.

note: orifice disc should not be used with this product.

Features

- Multiple function/application potential.
- Smooth shift transition.
- Low pressure drop.
- Tall cap version for higher bias springs 90, 110 and 160. The tall cap is also required when the valve is specified with manual override and the 40 size bias spring. Extra tall cap version for bias spring 240.
- Optional manual override only for 40, 90, 110, 160 and 240 psi bias springs.
- "G" metering option for metered flow control when opening.
- Industry common cavity.

Ratings

Pressure Ratings

Pressure rating 241 bar (3500 psi)

Flow Ratings

Flow rating 189 lpm (50 gpm)

Maximum internal leakage 164 ml/min (10 in³/min) - **Note:** At 3000 psi 207 bar

Temperature Ratings

Operating fluid temperature	-40 to 100 °C (-40 to 212 °F)	- Note: With buna N seals
	-26 to 204 °C (-15 to 400 °F)	- Note: With fluorocarbon seals
	-54 to 107 °C (-65 to 225 °F)	- Note: With polyurethane seals
Storage temperature	-40 to 70 °C (-40 to 160 °F)	
Ambient temperature	-40 to 70 °C (-40 to 160 °F)	

Operating Parameters

Fluids	Mineral based or synthetic hydraulic fluid with lubricating properties
Fluid viscosity range	7.4 to 420 cSt
Maximum operating contamination level	20/18/14 per ISO 4406. EV16-S34T EV16-S34 (reference all sheets) d:2.3 m:2.1 1-5/16-12 un-2a thread

Properties

Unit weight	0.29 kg (0.63 lb)	- Note: Ev16-s34-0-x-70
	0.41 kg (0.91 lb)	- Note: Ev16-s34t-0-x-160
	0.72 kg (1.58 lb)	- Note: Ev16-s34t-0-x-240
	0.57 kg (1.26 lb)	- Note: Ev16-s34tm-0-x-160
	0.86 kg (1.90 lb)	- Note: Ev16-s34tm-0-x-240
	Internal wetted surface area	367 cm ² (56.91 in ²)
292 cm ² (45.30 in ²)		- Note: Ev16s34tm0x160
287 cm ² (44.53 in ²)		- Note: Ev16s34t0x240
233 cm ² (36.12 in ²)		- Note: Ev16s34t0x160
182 cm ² (28.17 in ²)		- Note: Ev16s340x70



Performance

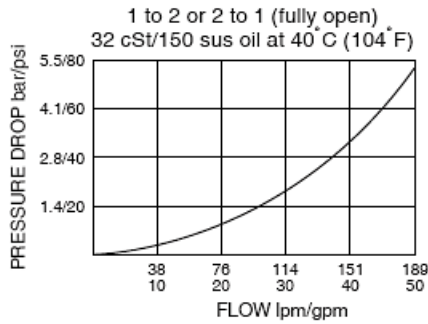

Dimensions

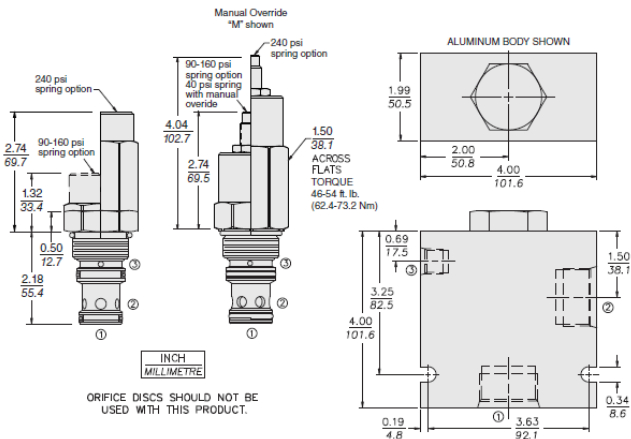

Installation Specifications

Cavity	VC16-S3
Cartridge installation torque	62.4 to 73.2 N-m (46 to 54 ft-lb)
Orientation restriction	None. D:2.3 m:2.1 flow gpm [lpm] pressure drop psi [bar] 0 30 [114] 20 [76] 10 [38] pressure drop VS flow 1 to 2 (fully open) 32 cSt at 104°F [40°C] 40 [151] 50 [189] 20 [1.4] 40 [2.8] 60 [4.1] 80 [5.5]

Accessories

Seal kit SK16-S3X-MM (x = seal option) - **Note:** X = seal option

Order Code

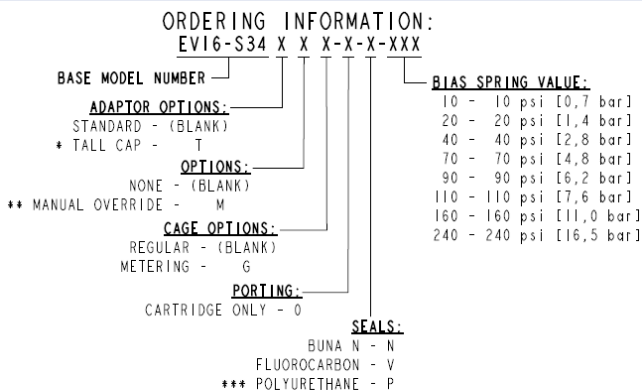

- * "T" TALL CAP REQUIRED FOR 90, 110, 160 AND 240 psi BIAS SPRINGS.
- ** "M" MANUAL OVERRIDE AVAILABLE WITH 40, 90, 110, 160 AND 240 psi SPRINGS ONLY.
- *** REQUIRED FOR PRESSURES OVER 3500 psi [241 bar].

Model Options

EV16-S34CDF-H-J-R

C Adaptor Option



CODE	DESCRIPTION
------	-------------

BLANK	Standard Cap
-------	--------------

T	Tall Cap
---	----------

D Cage Option

CODE	DESCRIPTION
------	-------------

BLANK	Standard Cage
-------	---------------

G	Metering (staggered holes)
---	----------------------------

F Stroke Limiter

CODE	DESCRIPTION
------	-------------

BLANK	Standard
-------	----------

M	Stroke Limiter
---	----------------

H Line Body

CODE	DESCRIPTION
------	-------------

0	No Body
---	---------

16T	Aluminum SAE 16
-----	-----------------

J Seal

CODE	DESCRIPTION
------	-------------

N	Buna-N
---	--------

V	Fluorocarbon
---	--------------

P	Polyurethane
---	--------------

U	PPDI Urethane
---	---------------

R Spring

CODE	DESCRIPTION
------	-------------

10	10 psi Bias Spring
----	--------------------

20	20 psi Bias Spring
----	--------------------

40	40 psi Bias Spring
----	--------------------

70	70 psi Bias Spring
----	--------------------

90	90 psi Bias Spring
----	--------------------

110	110 psi Bias Spring
-----	---------------------

160	160 psi Bias Spring
-----	---------------------

240	240 psi Bias Spring
-----	---------------------