



Overview

Description

The PS10-34 is a screw in, cartridge style, spool type, hydraulic sequence valve with internal pilot and spring chamber drain.

Operation

In its steady state, the PS10-34 blocks flow from port 1 to port 2, with the spring chamber drained at port 3. On attainment of a predetermined pressure at port 1, the cartridge shifts to open port 1 to port 2. The valve will remain shifted until the pressure in the circuit falls below the pressure setting. Note that the back pressure on port 3 adds to the spring setting value.

Features

- Adjustments cannot be backed out of the valve.
- Adjustments prohibit springs from going solid.
- Optional spring ranges to 117.2 bar (1700 psi).
- Hardened spool and cage for long life.
- Industry-common size.

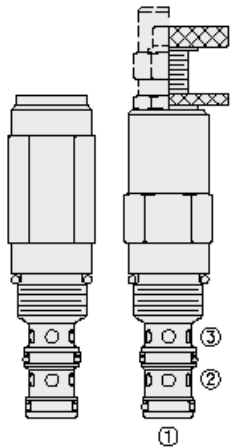

Symbol

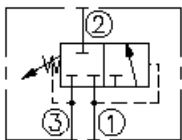

Ratings

Pressure Ratings

Pressure rating	206.8 bar (3000 psi)	- Note: Ports 1, 2
	103.4 bar (1500 psi)	- Note: Port 3
Proof pressure	517.1 bar (7000 psi)	
Burst pressure	965.3 bar (14000 psi)	
Crack pressure defined	Pressure evident at 0.95 lpm (0.25 gpm) attained port 1 to port 2	

Flow Ratings

Flow rating	56.8 lpm (15 gpm)	
Maximum internal leakage	82 ml/min (5 in ³ /min)	- Note: At port 3, to 85% of nominal setting

Temperature Ratings

Operating fluid temperature	-40 to 100 °C (-40 to 212 °F)	- Note: With buna N seals
	-26 to 204 °C (-15 to 400 °F)	- Note: With viton seals
Storage temperature	-40 to 70 °C (-40 to 160 °F)	
Ambient temperature	-40 to 70 °C (-40 to 160 °F)	

Operating Parameters

Fluids	Mineral based or synthetic with lubricating properties
Fluid viscosity range	7.4 to 420 cSt
Maximum operating contamination level	18/16/13 per ISO 4406

Properties

Unit weight	0.25 kg (0.56 lb)	- Note: PS10-34A
	0.30 kg (0.66 lb)	- Note: PS10-34C PS10-34L
	0.33 kg (0.73 lb)	- Note: PS10-34B
	0.24 kg (0.54 lb)	- Note: PS10-34F PS10-34H
Internal wetted surface area	172 cm ² (26.6 in ²)	- Note: PS10-34A PS10-34B PS10-34C PS10-34L
	196 cm ² (30.3 in ²)	- Note: PS10-34F PS10-34H



Performance

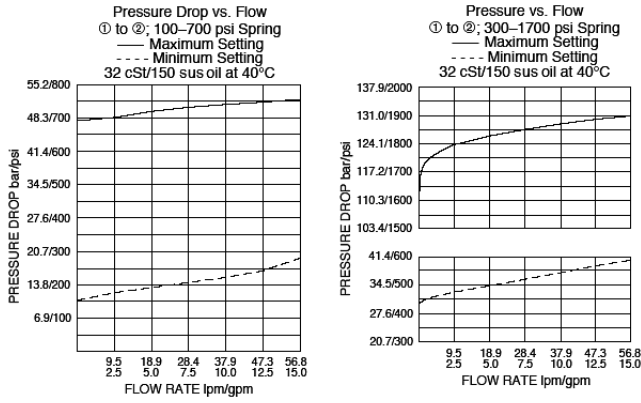

Dimensions

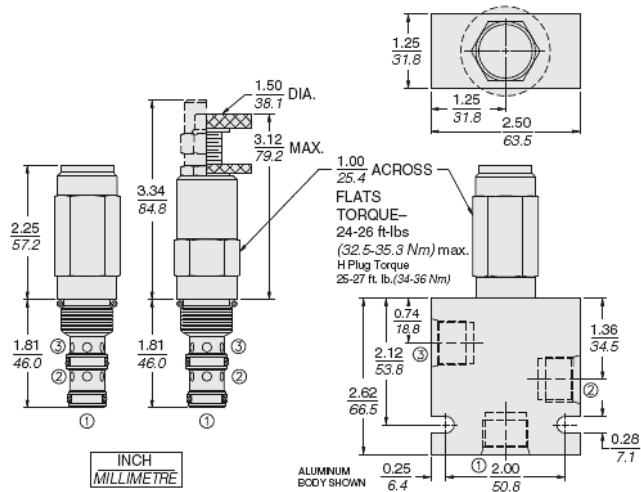

Installation Specifications

Cavity	VC10-3
Cartridge installation torque	32.5 to 35.3 N-m (24 to 26 ft-lb)
H style plug torque	33.9 N-m (25 ft-lb)
Orientation restriction	None

Accessories

Seal kit SK10-3X-BM - **Note:** X=seal options

Order Code

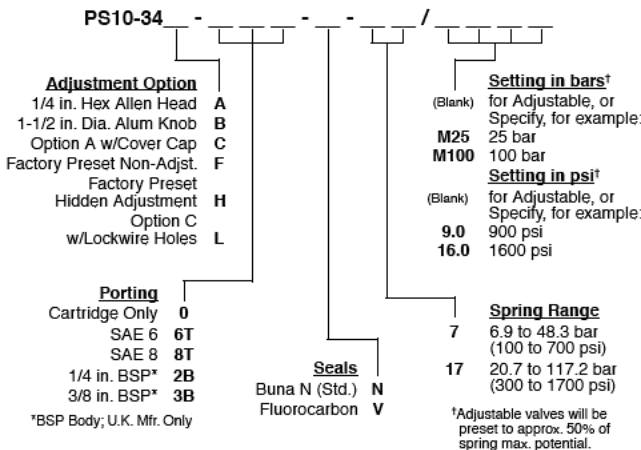

Model Options

PS10-34F-H-J-R/S



F Adjustment Option

CODE	DESCRIPTION
A	1/4" Hex Allen Head
B	1-1/2" Diameter Aluminum Knob with Aluminum Lock Knob
C	1/4" Hex Allen Head with Cover Cap
F	Factory Preset Non-Adjustable
H	Factory Preset Hidden Adjustment
L	1/4" Hex Allen Head with Cover Cap and Lockwire Holes

H Line Body

CODE	DESCRIPTION
0	No Body
6T	Aluminum SAE 6
8T	Aluminum SAE 8
6TD	Ductile Iron SAE 6
8TD	Ductile Iron SAE 8
3B	Aluminum BSPP 3/8" (3)
3BD	Ductile Iron BSPP 3/8" (3)

J Seal

CODE	DESCRIPTION
N	Buna-N
V	Fluorocarbon
P	Polyurethane
U	PPDI Urethane

R Spring

CODE	DESCRIPTION
07	6.9 to 48.3 bar (100 to 700 psi) Spring Range
17	20.7 to 117.2 bar (300 to 1700 psi) Spring Range

S Setting

CODE	DESCRIPTION
MXXX	Spring Setting in XXX bar
XX	Spring Setting in XX psi (x 100)