

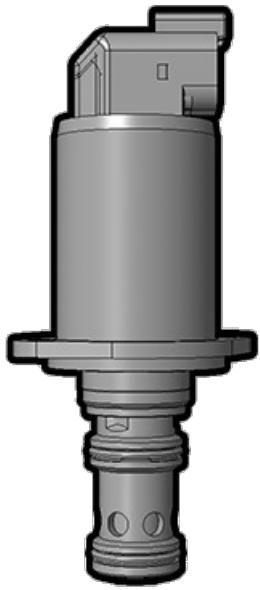

**Overview**



**Description**

The TS90-SG34 is a drop-in pilot operated (two stage), spool type hydraulic relief valve with pilot flow vented at port 3. It is a 3rd generation hydraforce drop-in, flange mounted cartridge type valve for use with mineral based or synthetic (with lubricating properties) hydraulic fluids. The coil is an integral part of the valve and is not serviceable. the regulated pressure is inversely proportional to the input electrical current.

**Operation**

TS90-SG34 is a spring biased valve that blocks flow from port 1 to port 2 until sufficient pressure is present at port 1 to open the valve by overcoming the preset induced by pilot spring force. With no current applied, the valve will relieve at the maximum pressure setting. Applying current to the coil decreases the induced spring force, thereby reducing the valve setting. port 3 provides drain of pilot flow to the tank.

**Features**

- Economical drop-in style.
- Optional lock-down flange.
- Several push-on termination options.
- Integral waterproof coil standard, IP69K, 960 hour salt spray per ASTM B117.

**Symbol**

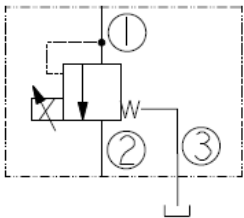

**Ratings**

**Pressure Ratings**

Pressure rating	40 bar (580 psi)	- <b>Note:</b> inlet
Proof pressure	241 bar (3500 psi)	- <b>Note:</b> Ports 1 and 2
	54 bar (780 psi)	- <b>Note:</b> Port 3
Burst pressure	310 bar (4500 psi)	- <b>Note:</b> Ports 1 and 2
	262 bar (3800 psi)	- <b>Note:</b> Port 4
Control pressure at zero current	35 bar (508 psi)	

**Flow Ratings**

Flow rating	80 lpm (21 gpm)	
Maximum internal leakage	45 ml/min (2.74 in <sup>3</sup> /min)	- <b>Note:</b> Combined from port 2 and 3 to 1 st 85% of crack pressure
Hysteresis	7 %	

**Other Ratings**

Cycle life	1 million cycles
Environmental rating	IP69k
Corrosion protection	960 hour salt spray per ASTM B117

**Temperature Ratings**

Operating fluid temperature	-20 to 120 °C (-4 to 248 °F)	- <b>Note:</b> With HNBR seals
	-26 to 204 °C (-15 to 400 °F)	- <b>Note:</b> With fluorocarbon seals
Storage temperature	-40 to 70 °C (-40 to 158 °F)	
Ambient temperature	-40 to 80 °C (-40 to 176 °F)	



## Operating Parameters

Fluids	Mineral based or synthetic hydraulic fluid with lubricating properties
Fluid viscosity range	7.4 to 420 cSt
Maximum operating contamination level	18/16/13 per ISO 4406

## Properties

Unit weight	0.30 kg (0.67 lb)
Internal wetted surface area	232 cm <sup>2</sup> (35.9 in <sup>2</sup> )

## Electrical Parameters

Maximum control current	1.05 A	- <b>Note:</b> S12 Coil (12 V)
	0.525 A	- <b>Note:</b> S24 Coil (24 V)
Dither PWM frequency	150 Hz	
Coil resistance	7.28 ohm	- <b>Note:</b> 12 V coil
	29.54 ohm	- <b>Note:</b> 24 V coil
Valve inductance	88 mH	- <b>Note:</b> Coil 12 V
	357 mH	- <b>Note:</b> Coil 24 V

## Performance

**RELIEVING PRESSURE VS FLOW CHARACTERISTIC AT VARIOUS CONTROL CURRENTS (20V)**

OIL: MOBIL DTE @ 104°F [40°C], 32 cSt

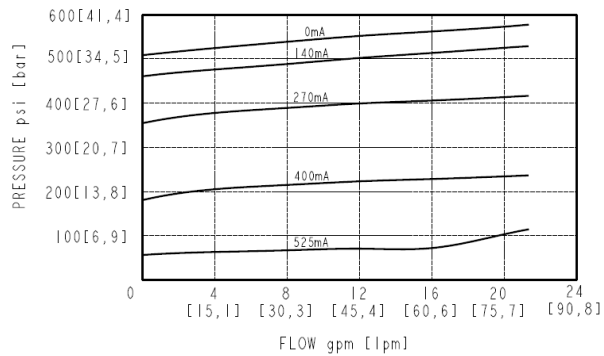

**RELIEVING PRESSURE VS CURRENT CHARACTERISTIC (20V)**

OIL: MOBIL DTE @ 104°F [40°C], 32 cSt, 2 gpm INLET

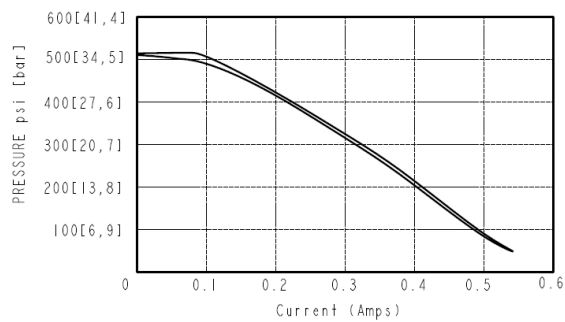



## Dimensions

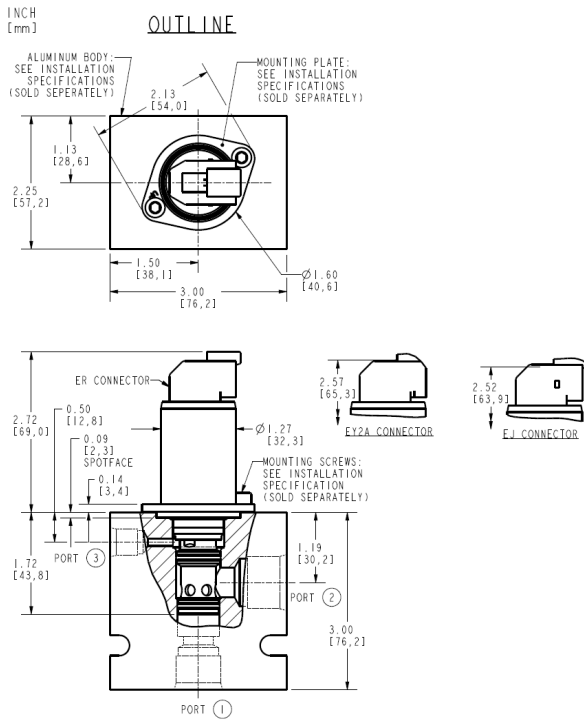

ALL DIMENSIONS ARE FOR REFERENCE ONLY.

## Installation Specifications

Cavity	VC-G041
Installation type	Flange mounted
Orientation restriction	None
Mounting screw torque	3 to 4 N-m (2.2 to 3.0 ft-lb)
Note	For retro-fitting into older drop-in cavities and other mounting options, see "Mounting-options-for-G3-valves" technical reference

## Accessories

Mounting plate	HF P/N 4595096
Mounting screw	M5 x 0,8 x 12 mm long, HF P/N: 4002609 (sold separately)
Seal kit	SK-G041-X - <b>Note:</b> X=seal option
Ported test body	HF P/N: 4611110



**Order Code**

**ORDERING INFORMATION**

**TS90-SG34-0-X-XXXX**

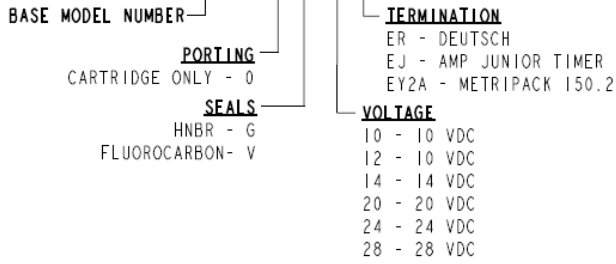

**Model Options**

**TS90-SG34-H-J-KL**

**H Line Body**

CODE	DESCRIPTION
0	No Body
10T	Aluminum SAE 10

**J Seal**

CODE	DESCRIPTION
G	HNBR (Hydrogenated Nitrile Butadiene Rubber)
V	Fluorocarbon

**K Coil Voltage**

CODE	DESCRIPTION
10	10 VDC
12	12 VDC
14	14 VDC
20	20 VDC
24	24 VDC
28	28 VDC

**L Coil Termination**

CODE	DESCRIPTION
EJ	E-Coil, AMP Jr.
ER	E-Coil, Deutsch
EY2A	E-Coil, Metri-Pack 150.2