

CV50-20 Check Valve, High Pressure

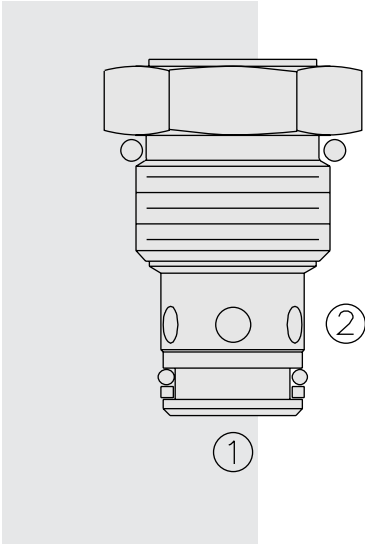

DESCRIPTION

A screw-in, cartridge-style, hydraulic check valve for use as a blocking or load-holding device for high pressure applications.

OPERATION

The CV50-20 allows flow passage from ① to ②, while normally blocking oil flow in the opposite direction.

The cartridge has a fully guided check which is spring-biased closed until sufficient pressure is applied at ① to open to ②.

FEATURES

- Hardened seat for long life and low leakage.
- Optional bias springs for back-pressure application flexibility.
- Fully guided check assembly.
- Industry common cavity.

RATINGS

Operating Pressure: 345 bar (5000 psi)

Flow: See Performance Chart

Internal Leakage: 0.10 cc/minute (2 drops/minute) max. at 345 bar (5000 psi)

Crack Pressure Defined: Gauge psi evident at ① at 16.4 cc/minute (1 cu. in./minute) attained

Standard Bias Springs at Crack: 0.34 bar (5 psi); 1 bar (15 psi); 2.1 bar (30 psi); 4.8 bar (70 psi)

Temperature: -40 to 120°C

Filtration: See page 9.010.1

Fluids: Mineral-based or synthetics with lubricating properties at viscosities of 7.4 to 420 cSt (50 to 2000 sus); See Temperature and Oil Viscosity, page 9.060.1

Installation: No restrictions; See page 9.020.1

Cavity: VC10-2; See page 9.110.1

Cavity Tool: CT10-2XX; See page 8.600.1

Seal Kit: SK10-2P-T; See page 8.650.1

SYMBOLS

USASI:

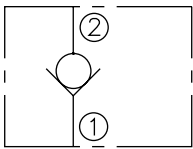

ISO:

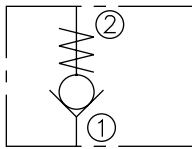

PERFORMANCE (Cartridge Only)

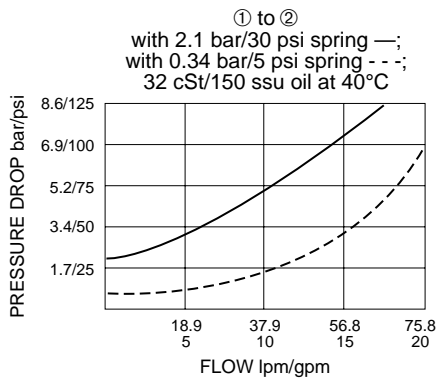

DIMENSIONS

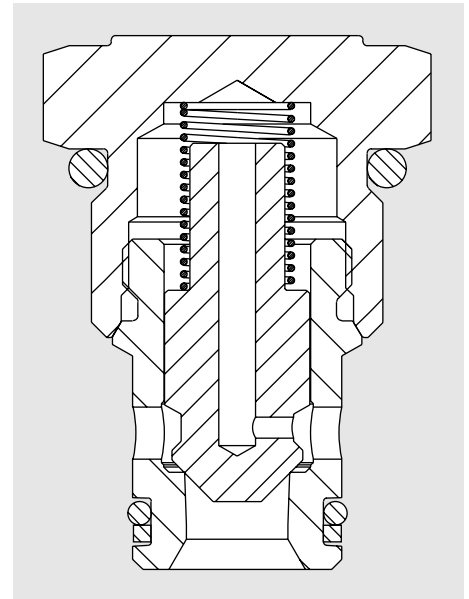
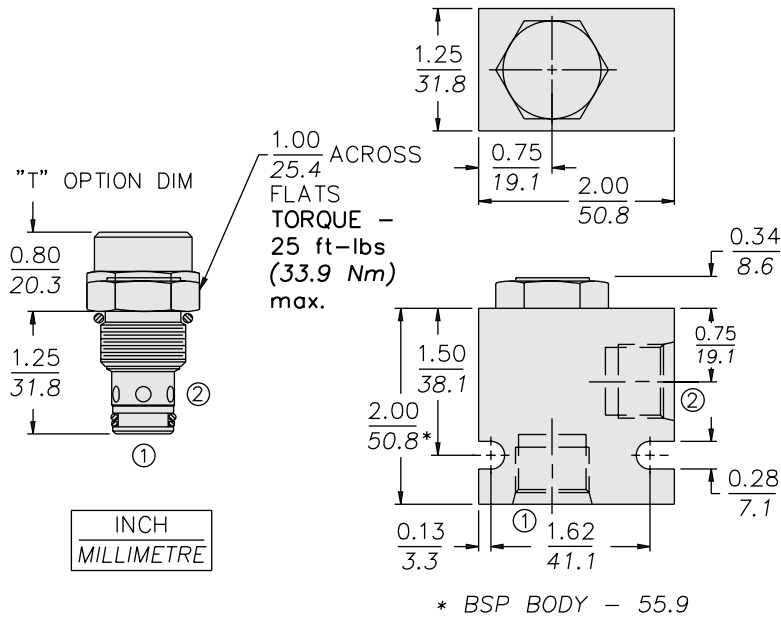

MATERIALS

Cartridge: Weight: 0.08 kg. (0.17 lbs.)
Steel with hardened work surfaces;
Zinc-plated exposed surfaces.
Polyurethane O-rings and
Fluorocarbon back-ups standard.

Ported Body: Weight: 0.43 kg.
(0.95 lbs.) Ductile Iron (code "D")
standard, consult factory for
weight, dimensions may differ;
rated to 345 bar (5000 psi).
See page 8.010.1.

TO ORDER

