

PD12-35 Piloted 2-Way Spool, Normally Open,

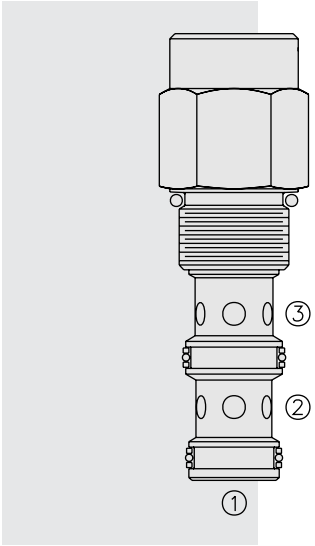

DESCRIPTION

A screw-in, cartridge-style, pilot-operated, spool-type, normally open hydraulic directional valve for two-way circuits requiring remote pilot actuation.

OPERATION

In neutral (unpiloted), the PD12-35 allows flow from ② to ③. The spring bias chamber is internally vented to ③.

On remote pilot signal at ①, the valve shifts to block ③ to ② bidirectionally.

Note: Back pressure at ③ will increase the pilot pressure required at ① to shift, at a ratio of 1:1. Consult factory.

Consult factory for applications where bi-directional flow is required when the valve is in the normal or spring-offset position.

FEATURES

- Hardened spool and cage for long life.
- Industry common cavity.

RATINGS

Operating Pressure: 240 bar (3500 psi)

Proof Pressure: 420 bar (6090 psi)

Flow: See Performance Chart

Internal Leakage: 82 cc/minute (5 cu. in./minute) max. at 207 bar (3000 psi)

Pilot Pressure Required: To Full Spool Shift for 7.6 bar (110 psi) spring:
8.6 bar (125 psi)

Oil Volume Required to Full Shift: 1.32 cc (0.08 cu. in.)

Temperature: -40 to 120°C with standard Buna seals

Filtration: See page 9.010.1

Fluids: Mineral-based or synthetics with lubricating properties at viscosities of 7.4 to 420 cSt (50 to 2000 sus); See Temperature and Oil Viscosity, page 9.060.1

Installation: No restrictions; See page 9.020.1

Cavity: VC12-3; See page 9.112.1

Cavity Tool: CT12-3XX; See page 8.600.1

Seal Kit: SK12-3X-MM; See page 8.650.1

SYMBOLS

USASI:

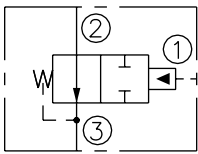

ISO:

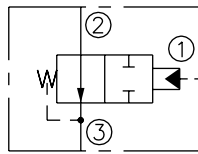

PERFORMANCE (Cartridge Only)

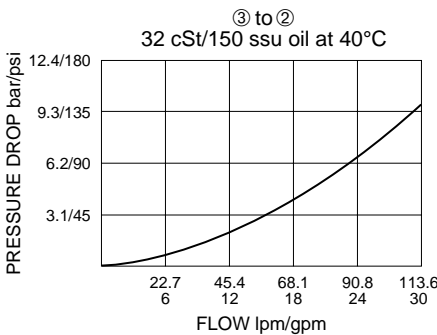

Internal Vent

PD12-35

DIMENSIONS

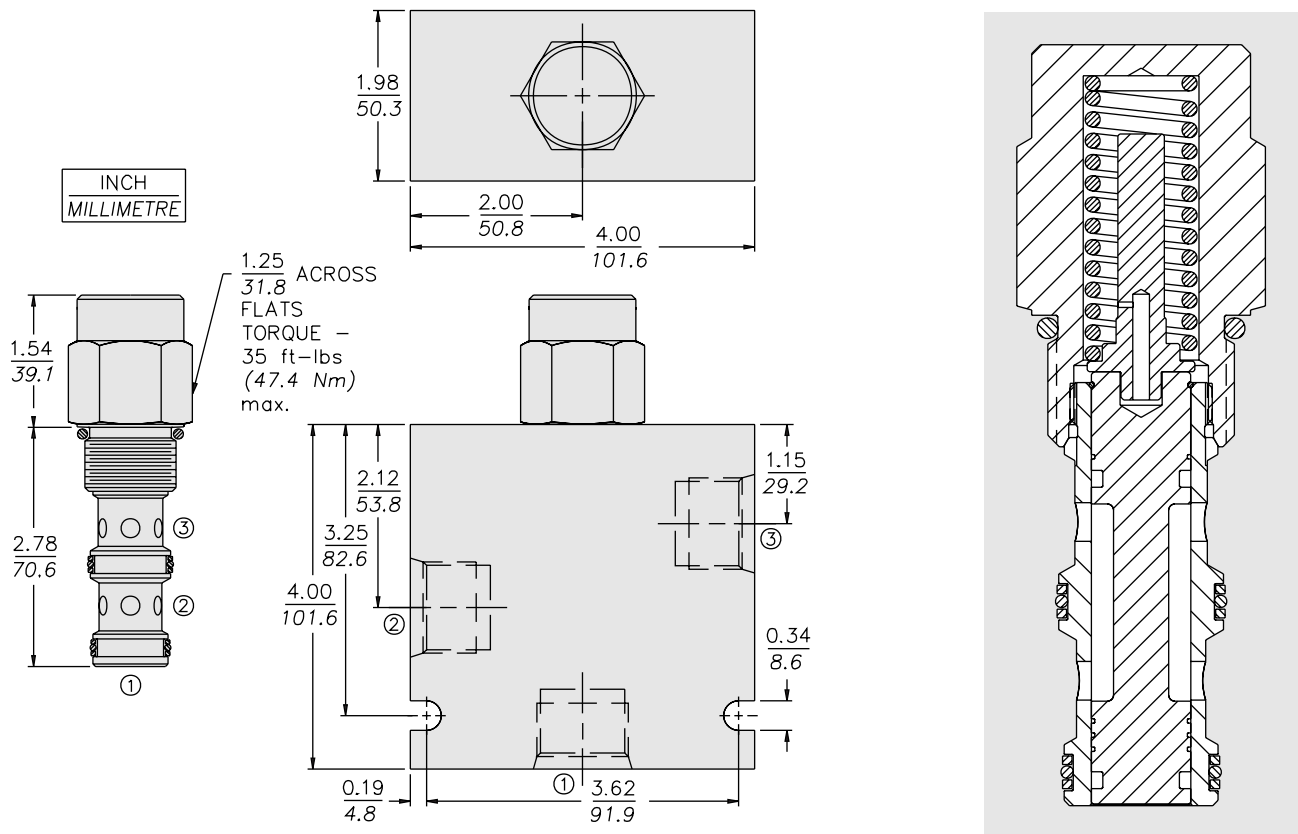

MATERIALS

Cartridge: Weight: 0.23 kg. (0.50 lbs.)
Steel with hardened work surfaces;
Zinc-plated exposed surfaces.
Buna N O-rings and polyester elastomer back-ups standard.

Standard Ported Body: Weight:
1.13 kg. (2.50 lbs.) Anodized high-strength 6061 T6 aluminum alloy, rated to 207 bar (3000 psi). Ductile iron bodies available; dimensions may differ. See page 8.012.1

TO ORDER

PD12-35 - - -

Porting
Cartridge Only **0**
SAE 8 **8T**
SAE 10 **10T**
SAE 12 **12T**
1/2 in. BSP* **4B**
3/4 in. BSP* **6B**

*BSP Body
U.K. Mfr. Only

Bias Spring
110 7.6 bar (110 psi)
170 11.7 bar (170 psi)

Seals
N Buna N (Std.)
NS Buna N with Sealed Spool
V Fluorocarbon
VS Fluorocarbon with Sealed Spool