

## PD16-S60N Piloted 4-Way Spool

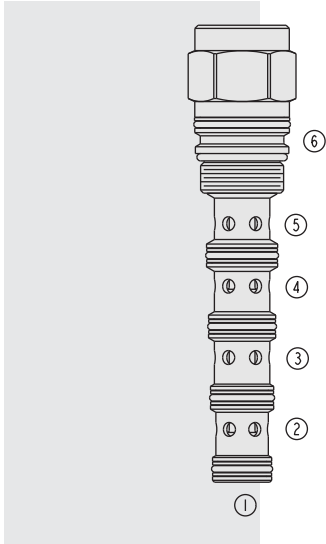

### DESCRIPTION

A screw-in, cartridge-style, pilot-operated, spool-type, hydraulic directional valve.

### OPERATION

In the neutral position, the **PD16-S60N** allows flow between ports ② and ③, and from ④ to ⑤. On remote pilot signal at ①, the valve shifts to allow flow between ③ and ④ and from ② to ⑤. The spring chamber is vented to the tank through port ⑥. The vented spring chamber allows the valve to be fully pressurized at ports ①, ②, ③ and ④ without affecting required pilot pressure. Pressure at port ⑥ will affect required pilot pressure.

### FEATURES

- Hardened spool and cage for long life.
- 60, 80, 110 and 170 psi bias springs available.

### RATINGS

**Operating Pressure:** 240 bar (3500 psi)

**Flow:** 0–95 lpm (0–25 gpm); See Performance Chart

**Maximum Internal Leakage:** at 207 bar (3000 psi): 164 ml/minute (10 cu. in./minute)

**Pilot Pressure Required:** 4.1 bar (60 psi) minimum

**Oil Volume Required to Full Shift:** 1.5 cc (0.09 cu. in.)

**Temperature:** -40 to 120°C

**Filtration:** See page 9.010.1

**Fluids:** Mineral-based or synthetics with lubricating properties at viscosities of 7.4 to 420 cSt (50 to 2000 sus); See Temperature and Oil Viscosity, page 9.060.1

**Installation:** No restrictions; See page 9.020.1

**Cavity:** VC16-S6; See page 9.116.1

**Cavity Tool:** CT16-S6XX; See page 8.600.1

**Seal Kit:** SK16-S6X-BMMMM; See page 8.650.1

### SYMBOLS

#### USASI:

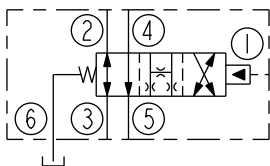

#### ISO:

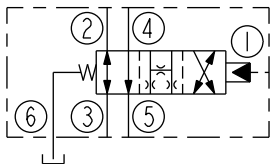

### PERFORMANCE (Cartridge Only)

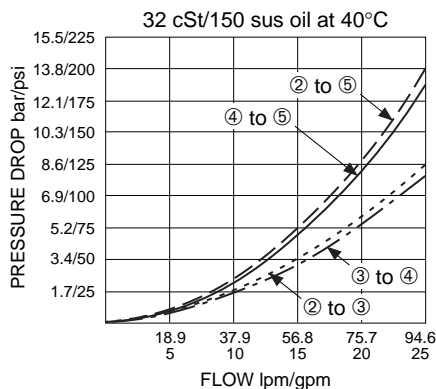

**DIMENSIONS**

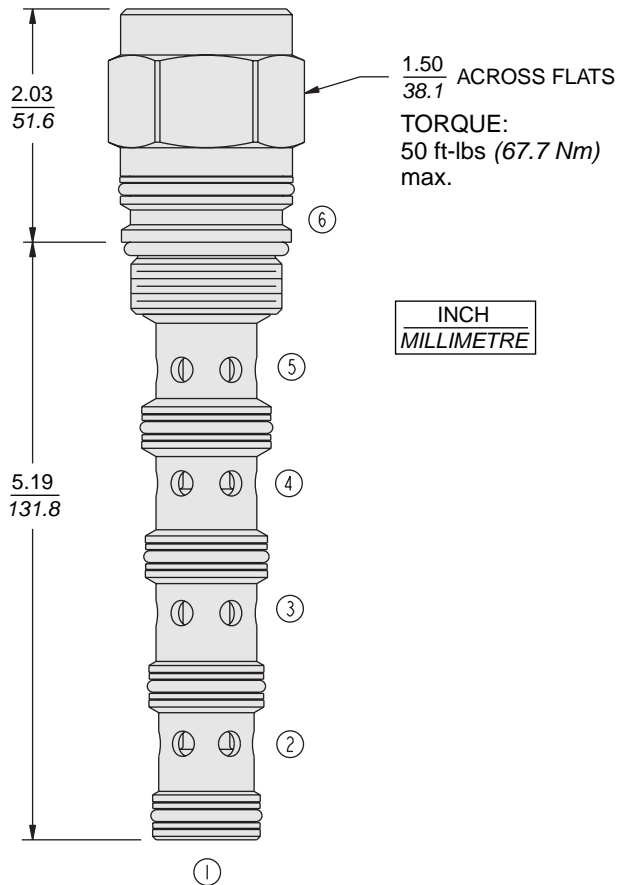

**MATERIALS**

**Cartridge:** Weight: 0.25 kg. (0.55 lbs.)  
Steel with hardened work surfaces.  
Zinc-plated exposed surfaces.  
Buna N O-rings and polyester elastomer back-ups standard.

**Ported Body:** Consult factory.

**TO ORDER**

PD16-S60N -

**Porting**  
Cartridge Only 0

**Bias Spring†**

- 60 4.1 bar (60 psi)
- 80 5.5 bar (80 psi)
- 110 7.6 bar (110 psi)
- 170 11.7 bar (170 psi)

Optional bias springs considered on OEM request.

\*Note: 110 psi bias spring is the minimum required for use with sealed spool.

**Seals**

- N Buna N (Std.)
- V Fluorocarbon
- NS Buna N w/Sealed Spool ① to ② only
- VS Fluorocarbon w/Sealed Spool ① to ② only