

MP10-41 Manual, Spring Return, Pull-to-Shift

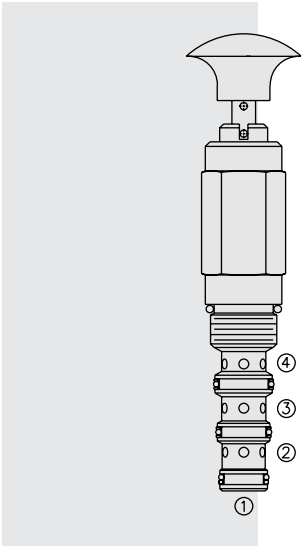

DESCRIPTION

A 4-way, manual, pull-to-shift, spring-return, screw-in, directional hydraulic cartridge valve.

Series operation is prohibited due to the tank port (1) pressure rating.

OPERATION

In its steady-state spring-offset position, the **MP10-41** blocks flow in all directions.

In the actuated (pulled) position, the cartridge directs flow from 3 to 4, and from 2 to 1.

Note: Pressure at port 1 will directly act on the spool and spring. Port 1 is intended to be a tank port only.

A unique pull-and-rotate feature for holding the positive actuated position is optional. A 90° rotation is required to position at the hold slot. The valve resets to spring-return de-actuated with a slight pull and a 90° turn from the locked actuated position.

FEATURES

- Hardened spool and cage for long life.
- Remains closed to 12.4 bar (180 psi) back-pressure.
- Optional rotational lock position.
- Industry common cavity.

RATINGS

Operating Pressure:

On 2, 3 and 4: 207 bar (3000 psi)

On 1 (Max.): 12.4 bar (180 psi)

Proof Pressure: 350 bar (5075 psi)

Flow: See Performance Chart

Internal Leakage: 82 cc/minute (5 cu. in./minute) max.

Mechanical Pull Effort Required: 7.3 kg. (16 lbs.) installed; 8.2 kg. (18 lbs.) to travel 3.2 mm (0.125 inch); 8.6 kg. (19 lbs.) to detent

Temperature: -40 to 120°C

Filtration: See page 9.010.1

Fluids: Mineral-based or synthetics with lubricating properties at viscosities of 7.4 to 420 cSt (50 to 2000 sus); See Temperature and Oil Viscosity, page 9.060.1

Installation: No restrictions; See page 9.020.1

Cavity: VC10-4; See page 9.110.1

Cavity Tool: CT10-4XX; See page 8.600.1

Seal Kit: SK10-4X-MMT; See page 8.650.1

SYMBOLS

USASI/ISO:

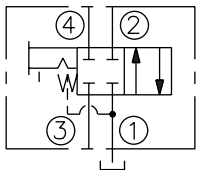

TRANSITION:

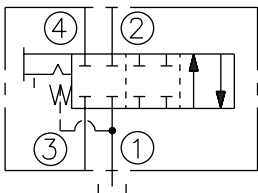

PERFORMANCE (Cartridge Only)

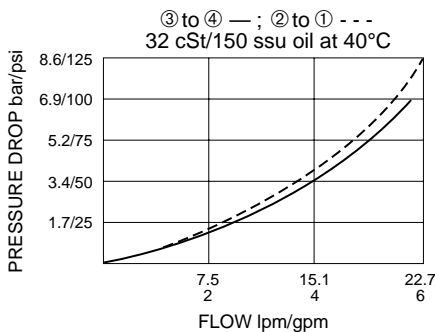

DIMENSIONS

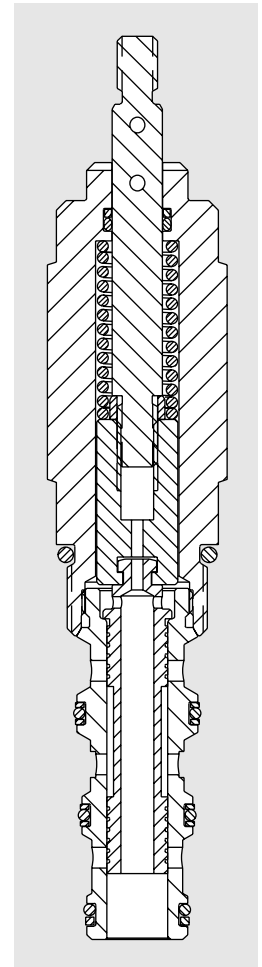
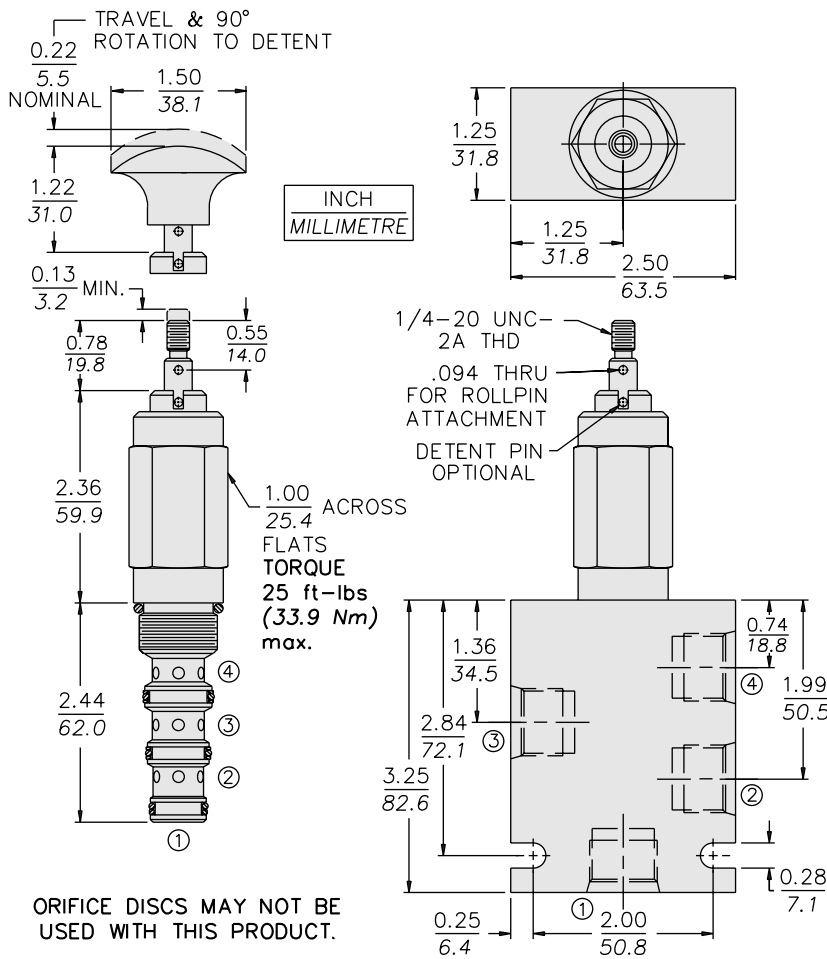

MATERIALS

Cartridge: Weight: 0.32 kg. (0.70 lbs.)
Steel with hardened work surfaces.
Zinc-plated exposed surfaces.
Buna N O-rings and polyester elastomer back-ups standard.
Plastic knob optional.

Standard Ported Body: Weight: 0.34 kg. (0.75 lbs.)
Anodized high-strength 6061 T6 aluminum alloy, rated to 207 bar (3000 psi). Ductile iron bodies available; dimensions may differ. See page 8.010.1.

TO ORDER

MP10-41		-	-	-
Option				Seals
Threaded Shaft/ Spring Return	T			N Buna N (Std.)
Threaded Shaft/ Lock Position Pin	R			V Fluorocarbon
<u>Black</u> Plastic Knob/ Spring Return	K			
<u>Black</u> Plastic Knob/ Lock Position Pin	D			Porting
<u>Red</u> Plastic Knob/ Spring Return	J			0 Cartridge Only
<u>Red</u> Plastic Knob/ Lock Position Pin	L			6T SAE 6
				8T SAE 8
				2B 1/4 in. BSP*
				3B 3/8 in. BSP*
				*BSP Body; U.K. Mfr. Only