

MR10-37B Manual Rotary, 3-Way, 3-Position

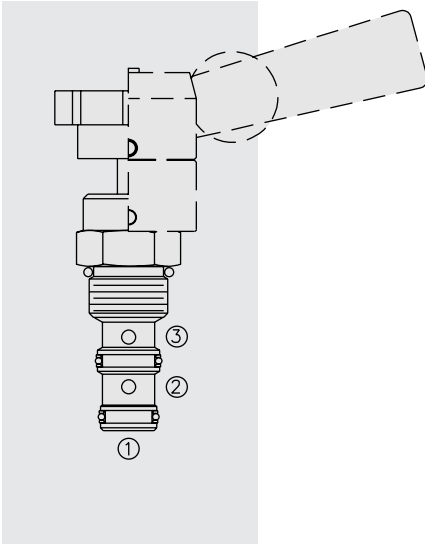

DESCRIPTION

Manually-operated three-way, three-position directional valve, with adaptability to a variety of adjustment operators (ordered separately), in a variety of spool configurations.

OPERATION

Three positions: centered, 45° counterclockwise, and 45° clockwise. In the center position all ports are open. In the 45° counterclockwise from center position, ports ② and ③ are open while port ① is closed. In the 45° clockwise from center position, ports ① and ② are open while port ③ is closed. All ports are partially open in transition.

FEATURES

- Three-position detent, friction lock (with detented neutral), or spring return operators may be ordered separately.
- May be fully pressurized at all ports.
- Optional lock-down bracket.
- Heavy-duty construction.
- Industry common cavity.

RATINGS

Operating Pressure: 240 bar (3500 psi)

Max. Flow: See Performance Chart

Internal Leakage: 164 cc/minute (10 cu. in./minute) at 240 bar (3500 psi)

Temperature: -40 to 120°C with standard Buna N seals

Fluids: Mineral-based or synthetics with lubricating properties at viscosities of 7.4 to 420 cSt (50 to 2000 sus); See Temperature and Oil Viscosity, page 9.060.1

Installation: No position restrictions; See page 9.020.1
See page 4.990.2 for operator handles/knobs installation;
See page 4.990.1 for lock-down bracket installation.

Cavity: VC10-3; See page 9.110.1

Cavity Tool: CT10-3XX; See page 8.600.1

Seal Kit: SK10-3X-MM; See page 8.650.1

Lock-Down Bracket Kit: Part Number 5399000

SYMBOLS

USASI/ISO:

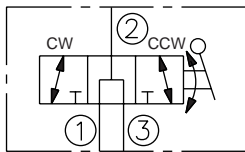

TRANSITION:

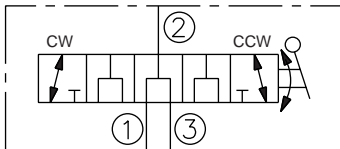

PERFORMANCE (Cartridge Only)

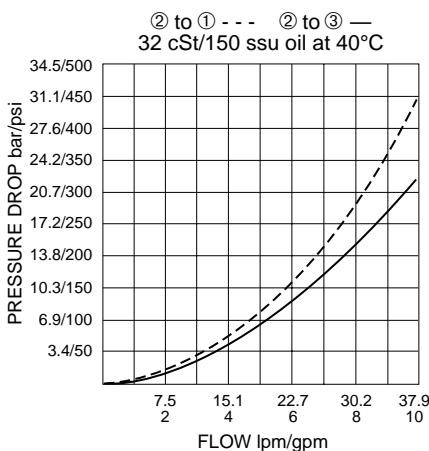

MR10-37B

DIMENSIONS

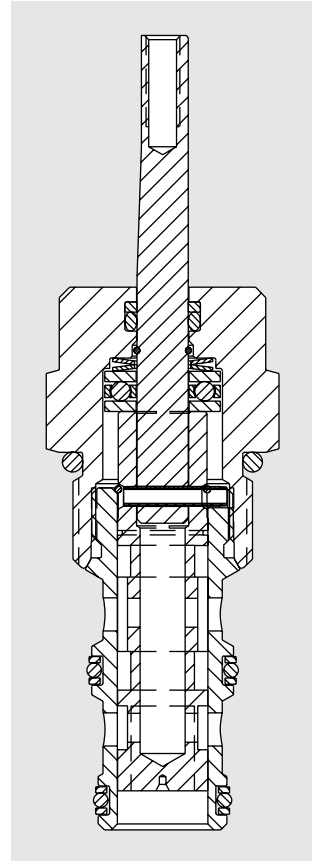
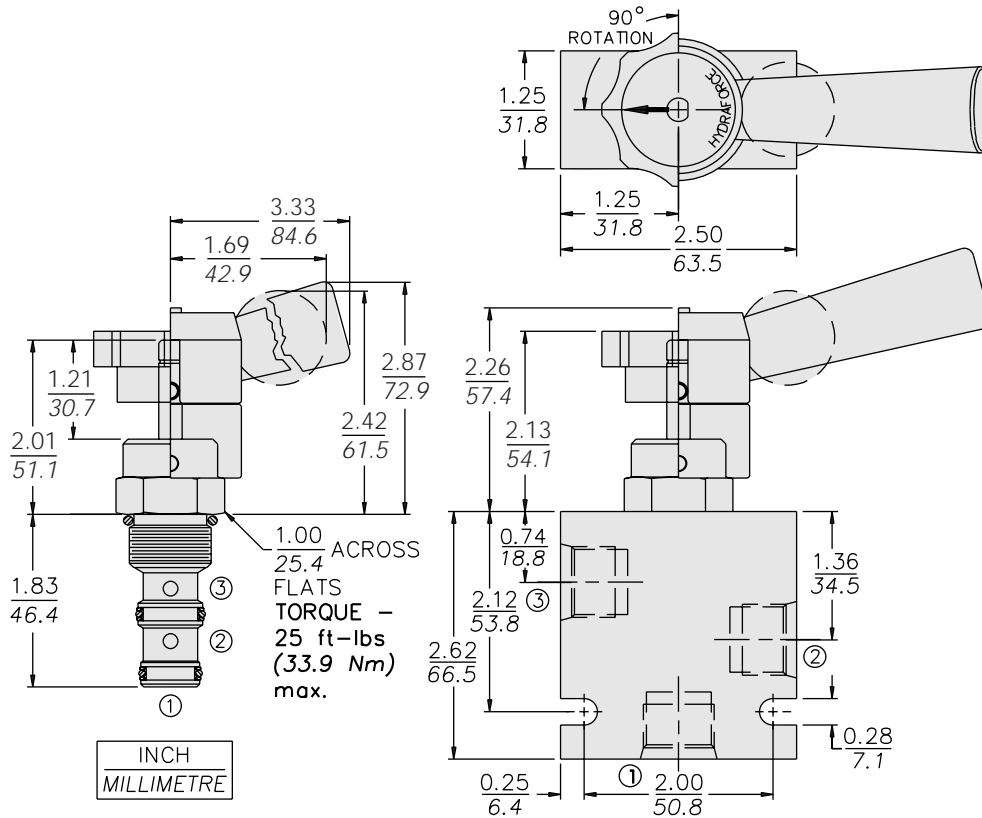

MATERIALS

Cartridge: Weight: 0.11 kg. (0.25 lbs.)
Steel with hardened work surfaces.
Zinc-plated exposed surfaces.
Buna N O-rings and Fluorocarbon back-ups standard.

Standard Ported Body: Weight:
0.32 kg. (0.70 lbs.) Anodized high-strength 6061 T6 aluminum alloy, rated to 207 bar (3000 psi). Ductile iron bodies available; dimensions may differ. See page 8.010.1

Lever-Type Handle: (Sold Separately)
Weight: 0.18 kg. (0.38 lbs.) Steel with hardened work surfaces.
Zinc-plated exposed surfaces.
Plastic lever arm.

TO ORDER

MR10-37B		-	-	-
Option				
None (Blank)				
Porting				
Cartridge Only			0	
SAE 6			6T	
SAE 8			8T	
SAE 8 with Lock-Down Bracket			8TL	
1/4 in. BSP*			2B	
3/8 in. BSP*			3B	
*BSP Body; U.K. Mfr. Only				

Seals
N Buna N (Std.)
V Fluorocarbon

NOTE: To order standard operator kits, refer to pages 4.770.1 and 4.770.2