

FR08-30F Regulator, Pressure-Compensated

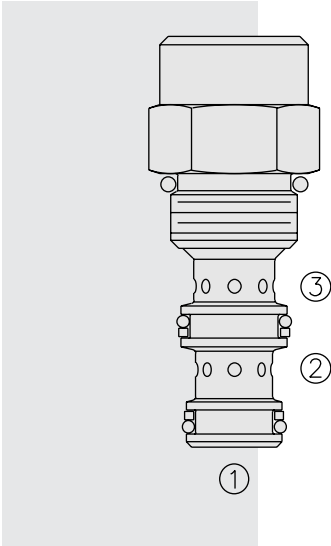

DESCRIPTION

A screw-in, cartridge-style, pressure-compensated, non-adjustable flow regulator, intended for use in fixed displacement hydraulic circuits requiring partial pump flow diversion on a priority basis.

OPERATION

The **FR08-30F** maintains a constant flow rate from ③ regardless of load pressure changes in the system downstream of ③, or in the bypass leg at ②.

The valve's spool maintains a constant differential pressure of 6.5 bar (95 psi) across a fixed internal orifice, thereby regulating the hydraulic flow rate from ① to ③.

The FR08-30F is a priority type regulator, delivering the pump flow to ③ first, then bypassing excess to ②. All ports may be fully pressurized.

Flow out of priority port ③ may vary based on input flow amount, particularly with lower temperatures and increased fluid viscosities. Settings may need to be established through correlation study. Consult factory.

FEATURES

- Hardened parts for long life.
- Quiet, modulated response.
- Compact size.

RATINGS

Operating Pressure: 207 bar (3000 psi)

Flow Rate: 7.6 lpm (2.0 gpm) max. regulated; 11.4 lpm (3.0 gpm) max. input.
Inlet pressure at ① begins to rise over the compensating differential when bypass flow exceeds 7.5 lpm (2 gpm)

Standard Compensator Bias Spring: 6.5 bar (95 psid) differential

Flow Maintenance Setting Range: 0.4 to 1.8 lpm (0.10 to 0.49 gpm) to accuracy of ±15%; 1.9 to 7.5 lpm (0.5 to 2.0 gpm) to accuracy of ±10%

Temperature: -40 to 120°C

Filtration: See page 9.010.1

Fluids: Mineral-based or synthetics with lubricating properties at viscosities of 7.4 to 420 cSt (50 to 2000 sus); See Temperature and Oil Viscosity, page 9.060.1

Installation: No restrictions; See page 9.020.1

Cavity: VC08-3; See page 9.108.1

Cavity Tool: CT08-3XX; See page 8.600.1

Seal Kit: SK08-3X-TB; See page 8.650.1

SYMBOLS

USASI:

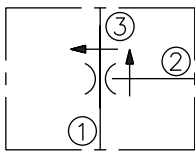

ISO:

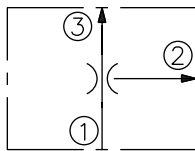

PERFORMANCE (Cartridge Only)

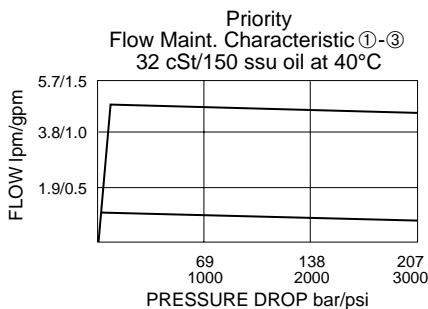

DIMENSIONS

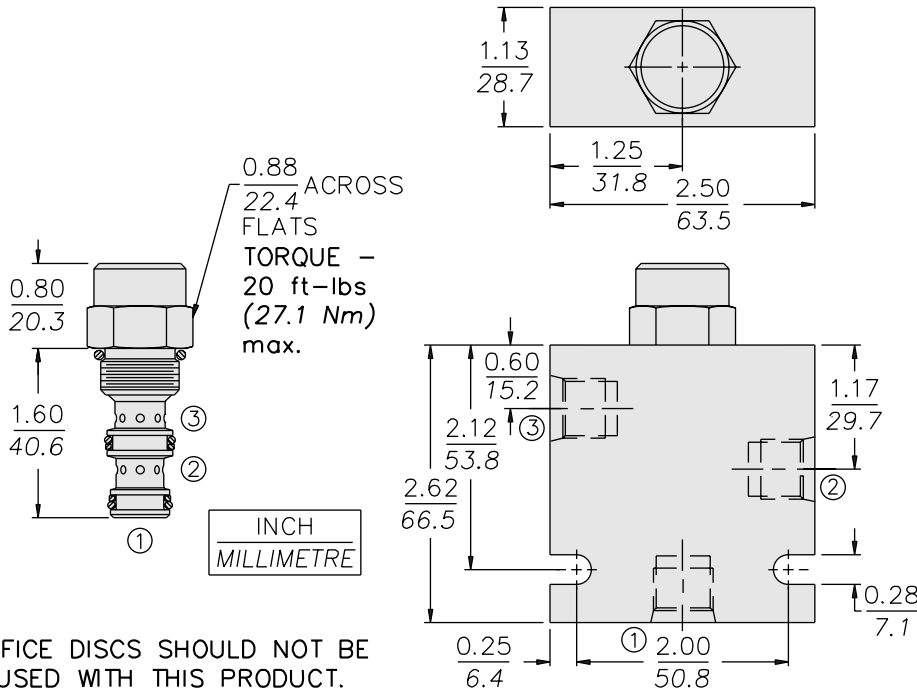

ORIFICE DISCS SHOULD NOT BE USED WITH THIS PRODUCT.

MATERIALS

Cartridge: Weight: 0.14 kg. (0.30 lbs.)
Steel with hardened work surfaces.
Zinc-plated exposed surfaces.
Buna N O-rings and back-ups standard.

Standard Ported Body: Weight: 0.27 kg. (0.60 lbs.)
Anodized high-strength 6061 T6 aluminum alloy, rated to 207 bar (3000 psi). Ductile iron bodies available; dimensions may differ. See page 8.008.1.

TO ORDER

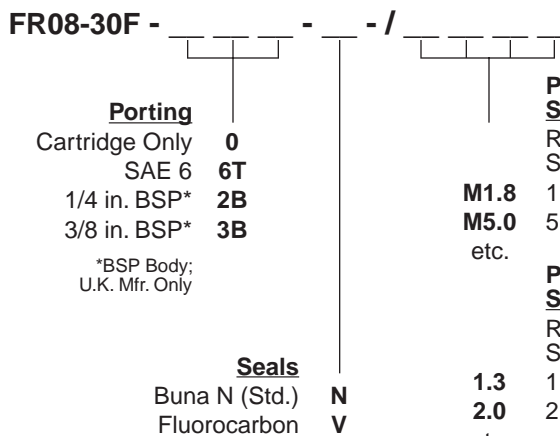

Priority Flow Setting in lpm
Range: 0.4 to 7.6 lpm
Specify, for example:

- M1.8** 1.8 lpm
- M5.0** 5.0 lpm
- etc.

Priority Flow Setting in gpm
Range: 0.1 to 2.0 gpm
Specify, for example:

- 1.3** 1.3 gpm
- 2.0** 2.0 gpm
- etc.

Priority Flow Drill Size Method

In thousandths of an inch;
Specify, for example:

- D030** 0.030 in. control orifice hole
- etc.

Note: Compensator spring values may be varied for OEM application to provide changed differential pressure/output flow relationships. Consult factory.

Note: Minimum drill diameter is 0.020 in. For smaller orifice sizes consult factory.