



The HydraForce HyPerformance™ Valve Advantage

*HPV16-30C-0-U-12ER

***THE H PREFIX INDICATES COMPLIANCE WITH OUR HYPERFORMANCE™ STANDARDS.**

Our HyPerformance™ brand valves offer the fluid power industry's highest level of hydraulic valve performance, enabling the most reliable application of cartridge valve technology in high duty cycle, high horsepower and high pressure equipment applications.

A full range of over 100 valves are available - each one tested in accordance with the rigid specifications of National Fluid Power Association (NFPA) standard T2.6.1.

- 350 bar (5075 psi) continuous operating pressure
- 420 bar (6090 psi) for operating pressure 10% of duty cycle
- Longer cycle life in lower pressure-rated applications
- Every valve and coil is 1000-hour salt spray rated in accordance with American Society for Testing and Materials (ASTM) standard B117
- Coils



All HyPerformance™ products are tested to the rigorous NFPA T2.6.1 standard specifications of 900,000 cycles at 350 bar/5075 psi and 100,000 cycles at 420 bar/6090 psi to ensure superior performance throughout the life of your machine.

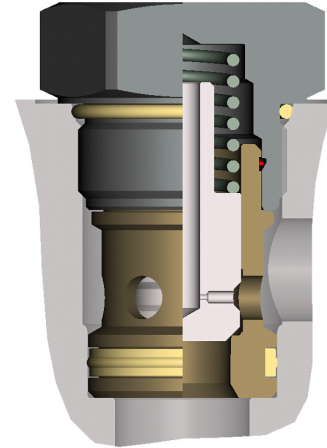

HydraForce valves have a HyTorque adaptor and cage that allow higher installation torque and improve valve retention.

- are IP69K and continuous-duty rated for extreme temperatures and low voltage conditions. They also pass the rigorous thermal shock dunk test.
- Every valve is fatigue tested to 420 bar (6090 psi) for 2 million cycles
- Every valve is 3-axis vibration tested up to 20G** RMS.
- Single piece, high endurance urethane seals are rated to 107µC (225µF)
- Improved cavity design makes valve performance insensitive to installation torque and ensures valve retention in high pressure applications
- U.S. patented solenoid tubes ensure that valve will shift under high pressure and flow

** Three-position tubes with two coils are tested to 15G RMS.

For detailed information and specifications, visit www.hydraforce.com or contact your local HydraForce representative at www.hydraforce.com/distributors/world.htm

HYDRAFORCE, INC.

500 Barclay Blvd. • Lincolnshire, IL 60069 USA
Ph: +1 847 793 2300 • Fx: +1 847 793 0086
Web: www.hydraforce.com • E-Mail: sales@hydraforce.com
ISO 9001 & QS 9000 • Member: National Fluid Power Association

HYDRAFORCE HYDRAULICS, LTD.

Advanced Manufacturing Hub
250 Aston Hall Road • Birmingham B6 7FE • United Kingdom
Ph: +44 121 333 1800 • Fx: +44 121 333 1810
Web: www.hydraforce.com • E-Mail: sales-uk@hydraforce.com
Member: British Fluid Power Association and
Verband Deutscher Maschinen-und Anlagenbau e.V. (VDMA)
ISO 9001 & ISO 14001

HYDRAFORCE HYDRAULIC SYSTEMS (CHANGZHOU) CO., LTD.

388 W. Huanghe Road • Building 15A
GDH Changzhou Airport Indl Park
Xinbei District • Changzhou, China 213022
Ph: +86 519 6988 1200 • Fx: +86 519 6988 1205
Web: www.hydraforce.com • E-Mail: sales@hydraforce.com
ISO 9001:2008