

CB10-30 Motion Control Valve

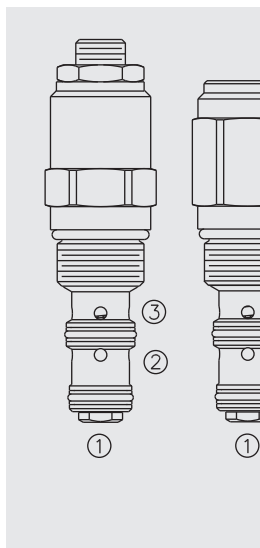

DESCRIPTION

A low leakage, pilot-operated motion control valve designed to regulate the lowering of over-running loads, while providing free reverse flow and thermal relief protection at the actuator.

OPERATION

The **CB10-30** is a low leakage, poppet-style control valve designed to restrict flow from port 2 to port 3 in relation to the pilot signal supplied at port 1. The valve includes free flow reverse flow and thermal relief protection at port 1. For maximum safety, motion control valves are designed to be screwed into an actuator or actuator mounted housing; or according to user specifications they can be incorporated into other manifold configurations.

FEATURES

- Adjustments cannot be backed out of the valve.
- Adjustments prohibit springs from going solid.
- Variety of adjustment options.
- Optional spring ranges to 207 bar (3000 psi).
- Hardened spool and cage for long life.
- Industry common cavity.

RATINGS

Operating Pressure: up to 207 bar (3000 psi)

Flow: up to 19 lpm (5 gpm); see performance chart

Internal Leakage: 10 drops per minute up to 85% of pressure setting

Pressure Setting Defined: Pressure evident at 15 to 25 drops per minute

Pilot Ratio: 7 to 1 load-assisted

Standard Spring Ranges:

Code 12: 0 to 83 bar (0 to 1200 psi) (Adjustment Option A only)

Code 22: 17 to 152 bar (250 to 2200 psi)

Code 25: 0 to 172 bar (0 to 2500 psi): (Adjustment Option F only)

Code 30: 55 to 207 bar (800 to 3000 psi)

Temperature: -40 to 120°C (-40 to 250°F) with standard Buna N seals

-35 to 204°C (-31 to 400°F) with fluorocarbon seals

-54 to 107°C (-65 to 225°F) with polyurethane seals

Filtration: See page 9.010.1

Fluids: Mineral-based or synthetics with lubricating properties at viscosities of 7.4 to 420 cSt (50 to 2000 sus); See Temperature and Oil Viscosity, page 9.060.1

Installation: No restrictions; See page 9.020.1

Cavity: VC10-3, Variation A; See page 9.110.1

Cavity Tool: CT10-3XX; See page 8.600.1

Seal Kit: SK10-3X-MM; See page 8.650.1

ISO SYMBOL

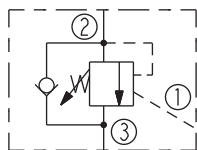

PERFORMANCE (Cartridge Only)

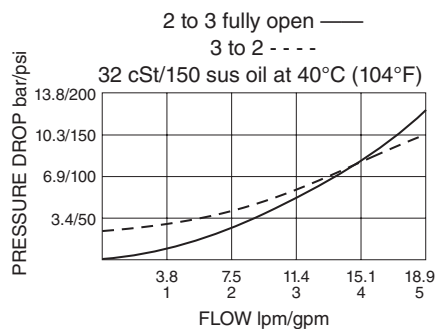

DIMENSIONS

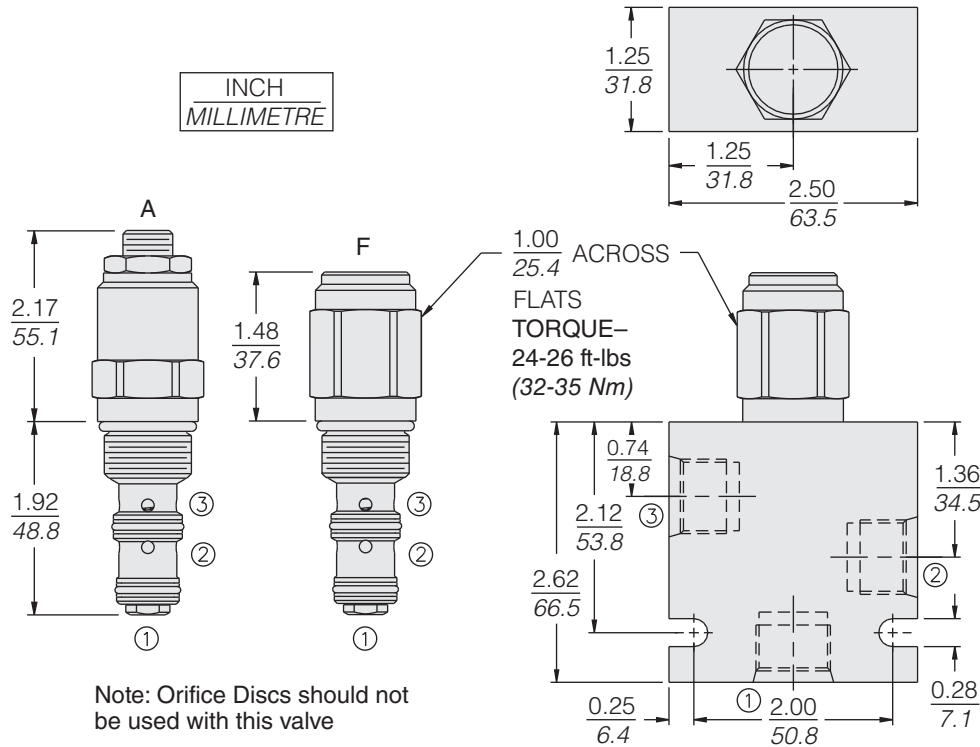

MATERIALS

Cartridge: Weight: 0.23 kg. (0.50 lbs.) with Adjustment Option A. 0.20 kg. (0.45 lb.) with Adjustment Option F. Steel with hardened work surfaces. Zinc-plated exposed surfaces. Buna N O-rings and polyester elastomer back-ups standard.

Standard Ported Body: Weight: 0.36 kg. (0.80 lbs.); Anodized high-strength aluminum alloy, rated to 240 bar (3500 psi). Ductile iron bodies available; dimensions may differ. See page 8.010.1.

TO ORDER

CB10-30 - - - /

Adjustment Option
*1/4 in. Hex Allen Head **A**
Factory Preset
Non-Adjustable **F**

*See page 6.003.1 for 'A-Alt' Fixed Height Adjuster details.

Porting
Cartridge Only **0**
SAE 6 **6T**
SAE 8 **8T**
1/4 in. BSP* **2B**
3/8 in. BSP* **3B**
*BSP Body; U.K. Mfr Only

Seals
Buna N (Std.) **N**
Fluorocarbon **V**
Polyurethane **P**

Setting in bar[†]
(Blank) for Adjustable, or Specify, for example:
M25 25 bar
M100 100 bar

Setting in psi[†]
(Blank) for Adjustable, or Specify, for example:
9.0 900 psi
21.0 2100 psi

[†]Adjustable valves will be preset to approx. 50% of spring max. potential.

Spring Range
12* 0 to 83 bar (0 to 1200 psi)
22 17 to 152 bar (250 to 2200 psi)
25** 0 to 172 bar (0 to 2500 psi)
30 55 to 207 bar (800 to 3000 psi)

* Spring Range 12 requires Adjustment option A.
** Spring Range 25 requires Adjustment option F.