

## SV08-33 Spool, 3-Way

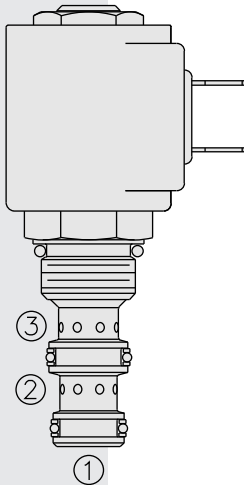

### ISO SYMBOL

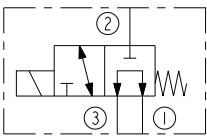

### PERFORMANCE (Cartridge Only)

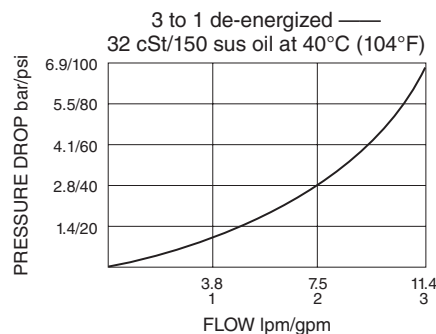

### DESCRIPTION

A solenoid-operated, 3-way, direct-acting, spool-type, screw-in hydraulic directional valve.

### OPERATION

When de-energized, the **SV08-33** allows flow from ③ to ①, while blocking flow at ②. When energized, the cartridge's spool shifts to open from ② to ①, while blocking at ③.

**Operation of Manual Override Option:** To override, push button in and twist counterclockwise 180°. The internal spring will push the button out. In this position, the valve may be only partially shifted. To assure full override shift, pull the button out to its fullest extension and hold it in this position.

To return to normal valve function, push button in, twist clockwise 180°, and release. Override will be detented in this position.

### FEATURES

- Continuous-duty rated solenoid.
- Hardened precision spool and cage for long life.
- Optional coil voltages and terminations.
- Efficient wet-armature construction.
- Cartridges are voltage interchangeable.
- All ports may be fully pressurized.
- Manual override option.
- Optional waterproof E-Coils rated up to IP69K.
- Unitized, molded coil design.
- Compact size.

### RATINGS

**Operating Pressure:** 207 bar (3000 psi)

**Proof Pressure:** 240 bar (3500 psi) without manual override

**Burst Pressure:** 620 bar (9000 psi) without manual override

**Flow Rating:** See Performance Chart

**Internal Leakage:** 82 ml/minute (5 cu. in./minute) max. at 207 bar (3000 psi)

**Temperature:** -40 °C to 100 °C (-40 to 212 °F) with standard Buna seals;

-26 °C to 204 °C (-15 °F to 400 °F) with fluorocarbon seals;

-54 °C to 107 °C (-65 °C to 225 °F) with polyurethane seals

**Coil Duty Rating:** Continuous from 85% to 115% of nominal voltage

**Initial Coil Current Draw at 20 °C:** Standard Coil: 1.2 A at 12 Vdc;

0.13 A at 115 Vac (full wave rectified).

E-Coil: 1.4 A at 12 Vdc; 0.7 A at 24 Vdc

**Minimum Pull-in Voltage:** 10.2 VDC (12 VDC coil)

**Filtration:** See page 9.010.1

**Fluids:** Mineral-based or synthetics with lubricating properties at viscosities of

7.4 to 420 cSt (50 to 2000 sus); See Temperature and Oil Viscosity, page 9.060.1

**Installation:** No restrictions; See page 9.020.1

**Cavity:** VC08-3; See page 9.108.1

**Cavity Tool:** CT08-3XX; See page 8.600.1

**Seal Kit:** SK08-3X-MM; See page 8.650.1

**Coil Nut:** Part No. 7004400;

For E-coils manufactured prior to 1-1-04, see page 3.400.1 for coil nut info.

**DIMENSIONS**

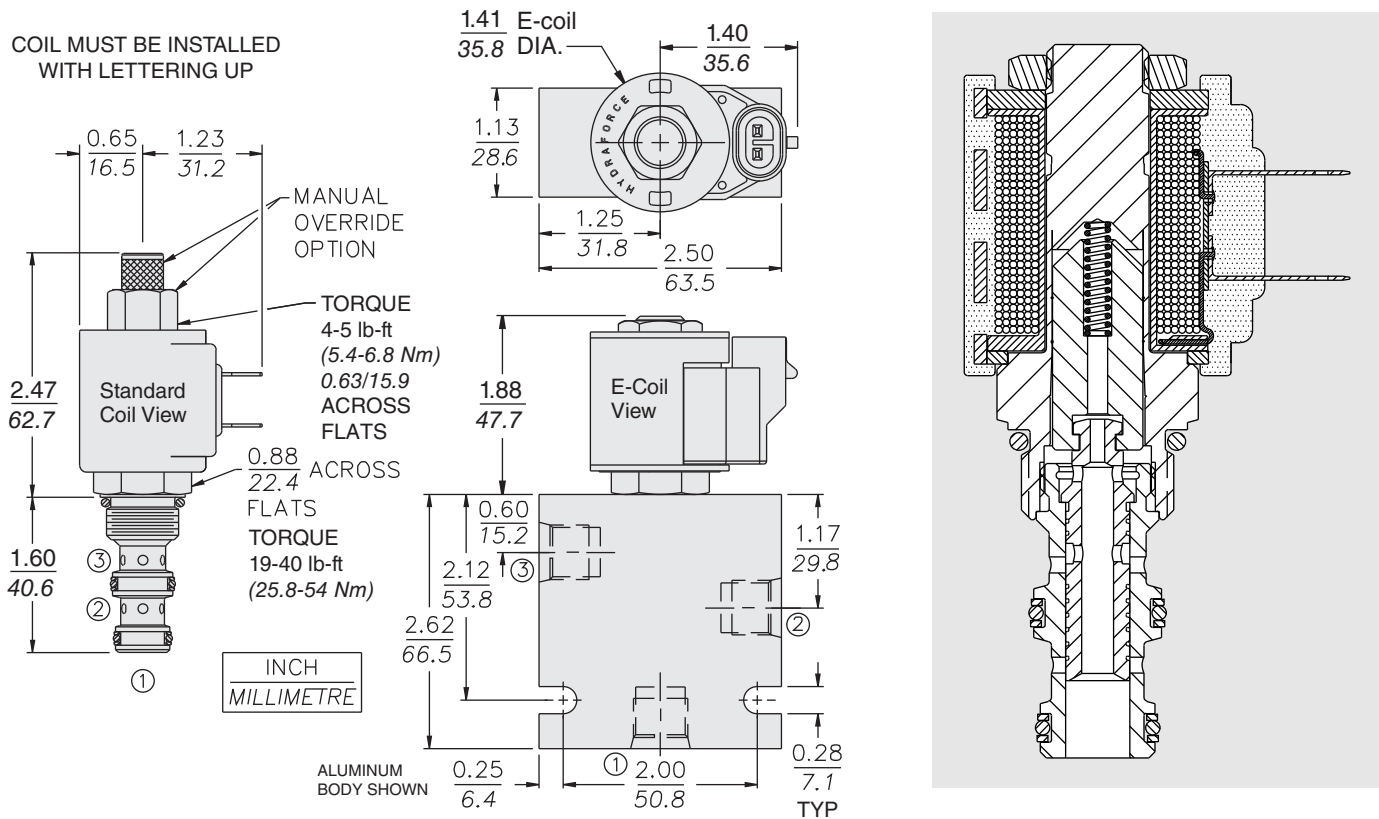

**MATERIALS**

**Cartridge:** Weight: 0.09 kg (0.20 lb); Steel with hardened work surfaces. Zinc-plated exposed surfaces; Buna N O-rings and back-ups standard.

**Standard Ported Body:** Weight: 0.27 kg (0.60 lb); Anodized high-strength aluminum alloy, rated to 207 bar (3000 psi); Ductile iron bodies available; dimensions may differ. See page 8.008.1.

**Standard Coil:** Weight: 0.11 kg (0.25 lb); Unitized thermoplastic encapsulated, Class H high temperature magnet wire. See page 3.200.1.

**E-Coil:** Weight: 0.14 kg (0.3 lb); Perfect wound, fully encapsulated with rugged external metal shell; Rated up to IP69K with integral connectors. **See page 3.400.1 for all E-Coil retrofit applications.**

**TO ORDER**

**SV08-33**

<b>Option</b>	<b>Voltage</b>
None (Blank)	<b>Std. Coil</b>
Manual Override <b>M</b>	<b>0</b> Less Coil**
	<b>10</b> 10 Vdc†
	<b>12</b> 12 Vdc
	<b>24</b> 24 Vdc
	<b>36</b> 36 Vdc
	<b>48</b> 48 Vdc
	<b>24</b> 24 Vac
	<b>115</b> 115 Vac
	<b>230</b> 230 Vac
	**Includes Std. Coil Nut
	† DS, DW or DL terminations only.
<b>Porting</b>	<b>E-Coil</b>
Cartridge Only <b>0</b>	<b>10</b> 10 Vdc
SAE 6 <b>6T</b>	<b>12</b> 12 Vdc
3/8 in. BSP* <b>3B</b>	<b>20</b> 20 Vdc
*BSP Body; U.K. Mfr. Only	<b>24</b> 24 Vdc
<b>Seals</b>	
Buna N (Std.) <b>N</b>	
Fluorocarbon <b>V</b>	

<b>Coil Termination</b>	<b>E-Coil</b>	<b>D-Coil</b>
Deutsch DT04-2P	<b>ER</b> (IP69K)	<b>DR</b> (IP65)
Metri-Pack® 150	<b>EY</b> (IP69K)	<b>DY</b> (IP65)
Dual Lead Wires	<b>EL</b> (IP69K)	<b>DL</b> (IP65)
Amp Jr. Timer	<b>EJ</b> (IP67)	—
DIN 43650	<b>EG</b> (IP65)	<b>DG</b> (IP65)
Dual Spades	—	<b>DS</b> (IP65)

For Coils with Zener Diode, add "Z" to option code. For example: "ER/Z". Not available on all models. See coil option info. on pages 3.200.1 & 3.400.1